

Principals

Thomas Allsup

Manager of Technology

Thomas received his BSME from Oklahoma State University. In 1990, Thomas got his MSME from University of Texas at Arlington. Thomas ended his PhD in Mechanical Engineering from UTA as an All-But-Dissertation in 1994. Thomas is currently working towards his General Engineering PhD online from Kennedy Western University. Thomas has spent seventeen years as a design engineer in consumer products, semiconductor devices, and burn-in sockets. Thomas has one patent and two pending.

Ray Blasingame

Manager of Engineering

After four years in the Air Force, Ray received his BSEE from Oklahoma State University. Ray has spent thirty years in the electronics area at TI, Honeywell, and several little companies. Ray has three patents and six pending.

Garry Stevens

Manager of Manufacturing

After three years in the Marines, Garry spent the next eighteen years in the semi-conductor industry working his way up from technician to process engineer at various companies such as Honeywell and TRW. In 2002, Garry completed his Associates Degree and is currently working on his BSCS degree on-line.

anida
technologies

Technical
Consultants

anida
technologies

2089 N. Collins Blvd.
Suite 201A
Richardson, TX 75080
972.480.0110
Fax 972.701.0359
www.anidatech.com

Providing Turnkey Solutions
from Concept to Production
and Anything In Between

Sample Projects

- Custom Fixtures for HAST, Burn-In, and Vibration Testing

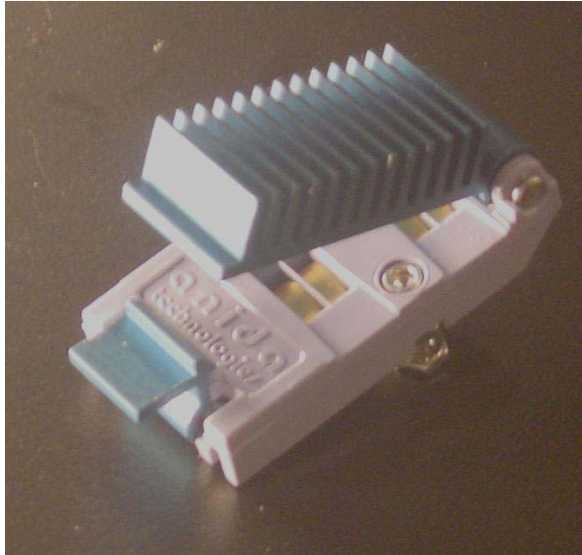

- Custom Equipment Design and Fabrication

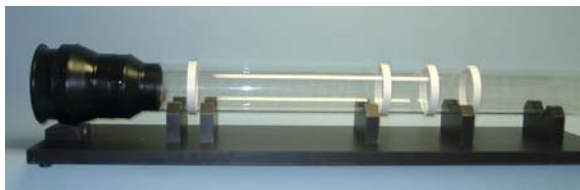

- Custom Ultra-Low Spring Force Test Fixture

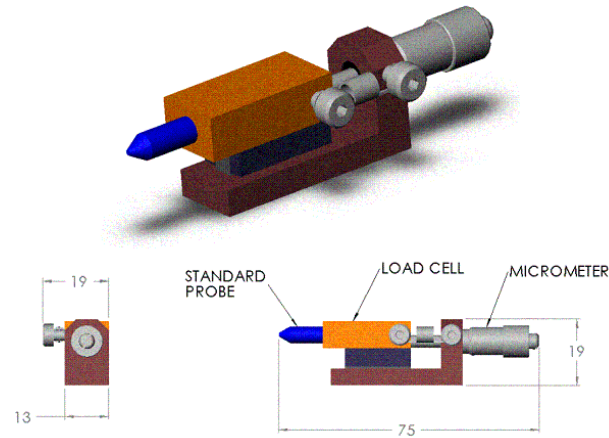

- Custom Test, Automation and Analysis Software Development

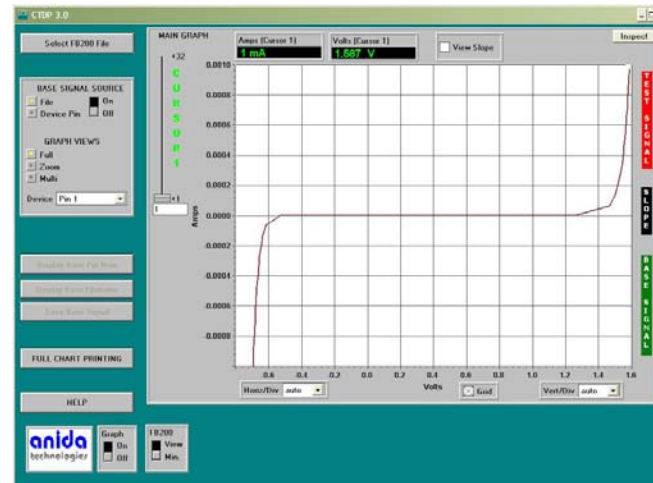

- Total Engineering Analytical and Empirical Studies

- Dimensional
- Structural
- Thermal

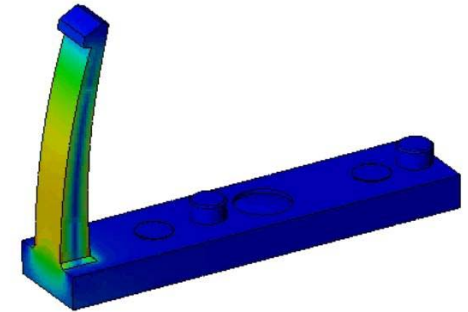

- Training and Seminars
 - Geometric Dimensioning and Tolerances
 - Design For Manufacturing and Assembly
 - Computer Aided Design

